

MODEL H66-20

SERIAL # 2007-8899999

2270 Industrial boul. , Montreal (Laval), Canada, H7S 1P9
Tel.: (450) 667-9769, Fax: (450) 667-6320



INSTRUCTION **MANUAL**

**FOR ALL INQUIRIES
PLEASE CONTACT
OUR LOCAL DISTRIBUTOR**

**FOR NORTH AMERICA ONLY
1-800-333-6556**

Thank you for choosing ORION stretch-wrapping equipment. It is a wise choice, which will benefit your company now and in the future.

ORION uses a unique combination of functional, rugged steel structure and sophisticated control systems to offer equipment high in durability and low in maintenance requirements. Our advance control systems mean that Orion equipment can be operated safely and efficiently without the need for special operator expertise.

Please read this manual carefully and keep it handy. Following these simple operating instructions will insure the safe and efficient performance of this machine while simple maintenance procedures will guarantee a long and productive life of the equipment.

Notice:

Our manual covers standard features of the machine. Certain options may not be fully covered due to their unique application.

In order to acquire more information about custom made features of your machine and to provide quicker service, the following information is required when making an inquiry:

1)Model

2)Serial Number **2007-8899999**

3)Subassembly (see PART LIST)

SAFETY:

ORION'S stretch wrappers should be operated with caution and common sense as any other industrial equipment. To prevent injury and/or electrical shocks, careful operation of the machine and awareness of its many automatic functions is required.

NOTE: All electrical power and compressed air must to be disconnected prior to all inspection, maintenance or repair work.

ORION PACKAGING INC.

ORION PACKAGING SYSTEMS INC.

SEMI-AUTOMATIC SPECIFICATIONS

ORION MATRIX® SERIES MODEL H-66

Spiral Semi-Automatic Medium Duty High Profile

Maximum Load Size	55"W x 55"L x 82"H
Weight Capacity	4,000 lbs. Dynamic, 8,000 lbs. Static
Utilities	115 / 1 / 60 ; 15 Amp Service
Turntable	48" x 48" Formed & Welded Octagonal Turntable w/skirt Structural Steel Plate 8 Caster Dura-Glide™ Support System
Turntable Drive	0 - 14 RPM Variable Turntable Speed Variable Speed Drive Motor Direct Heavy Duty ANSI Chain & Sprocket Drive Electronically Adjustable Acceleration/Deceleration (Soft Start) Positive Alignment Feature
Control Features	CSA Approved, NEMA 12 Control Panel State-of-the-Art Allen Bradley MicroLogix Programmable Logic Controller User Friendly Controls with Non-Proprietary Pushbuttons, and Switches Revo-Logic™ Exact Wrap Counting Technology Electronic Film Tension Control Adjustment on the Panel End of Cycle Film Force Release Separate Top and Bottom Wrap Count Selectors Variable Speed & Separate Film Carriage Up/Down Controls Film Carriage Raise/Lower Switch (Manual) Cycle Pause for Stopping the Wrap Cycle Without Resetting Reinforce Wrap for Banding Photocell for Automatic Load Height Detection with On/Off Switch Turntable Jog Pushbutton Selectable Bottom Wraps First / Top Wraps First Operation
Film Delivery	20" Orion Insta-Thread™ Powered Prestretch Film Delivery System Precision Ground, Polyurethane Pre-Stretch Rollers for Consistent, Maximum Film Yield 260% Standard Pre-Stretch Ratio (Maximum 395%) Easy & Safe to Operate Self-Threading Carriage Design Electronic Film Tension Control Adjustment on the Panel Full Authority Film Dancer Bar with Variable Speed Output (Non-Wearing Sensor) Heavy Duty ANSI Chain & Sprocket Ratio Control Adjustable Film Roping Bar on Chassis for Stronger Interlocking of Load and Pallet
Film Carriage Elevator Drive	Heavy Duty ANSI Chain Carriage Lift Variable Speed Drive Motor Multi-Point UHMW Precision Carriage Guidance System
Structural Features	100% Structural Steel Construction Throughout Non-Proprietary, Locally Obtainable Components Throughout Easy Access to All Components Open Mechanical Design for Ease of Maintenance Forklift Portable Base Design Structural Steel Tube Mast Design Hinged Mast for Ease of Shipping, Portability
Estimated Shipping Weight	1,200 lbs.

Visit our Distributor Support Website at www.support.orionpackaging.com

MACHINE UNLOADING INSPECTION & INSTALLATION

UNLOADING

Machine can be easily unloaded and transported by a forklift with a minimum capacity of 2500 lbs.

1. Carefully insert the forks into the lifting tubes to the maximum possible depth. Depending on the model, a forklift access may be either at the turntable end of the machine frame, the tower end or both. In case of the mongoose machine enter the forks under the frame or insert the forks in the tube brackets welded to the top of the machine.

2. Lift the machine (or other part of system) only to the necessary height to move it with no bouncing or friction on the floor.

3. Sit the machine down assuring uniform contact with the floor, which is necessary to ensure correct and smooth operation.

INSPECTION

1. Remove all packing and supporting additions - these may include the blocks under the carriage and the restraining bar over the table.

NOTE: when removing the stretchwrap film covering the machine, care must be taken not to cut any of the electrical wires and/ or polyurethane covering on the film carriage rollers.

2. Perform a visual inspection of the electrical and mechanical parts for loosened joints and / or broken connections. Any suspected shipping damage must be reported immediately to the freight carrier. Any transport damage cannot be claimed to Orion Packaging Inc.

Items that are vulnerable to damage and must be inspected are as follows:

- Motors and transmissions
- Junction boxes
- Electrical conduits
- Proximity and limit switches
- Photocells

3. Check under the turntable to ensure that there is no crippling of the movable parts i.e. casters, center axle or drive assembly.

4. Verify the following:

- Turntable or rotary arm drive system to confirm that the reducer to drive the chain is snug and properly aligned.

- Verify the wires tight conduits for crushed sections or loose fittings.

- Verify the film carriage to be sure that it is correctly aligned with the tower

- Verify the tension on the lift chain.

- Verify all the dials and knobs on the control panel for smooth action.

MACHINE INSTALLATION

After the visual inspection has been completed, the electrical power and the compressed air shall be connected as specified on the diagrams supplied with the machine. An electrical diagram is provided with each machine in the envelope attached to the panel box.

ASSEMBLY PROCEDURE

The structural frames of the machine have to be installed on a leveled floor. Locate the main wrapper section into its final position, keeping the tower assembly* away from any traffic. The wrapper mainframe section **must be bolted to the floor by the 1/2" concrete floor anchors** (leg & shield or expandable type).

Any wiring that has been disconnected to facilitate transport is marked with a number located on the junction box to which the wiring must be reconnected. Any wire run that appears too short or long may indicate that the position of the mechanical components is incorrect. Verify the status of all assemblies before proceeding.

* The tower deviation from vertical must not exceed 1/4" on the distance of 10 feet (angle: 0 degrees 6').

CONTROL PANEL

In the case of the free standing panel (console) place it adjacent to the system and anchor firmly to the floor. Connect the liquid tight (rigid conduit) to the main junction box located on the wrapper main frame next to the tower.

Before Starting Machine Operation

Verify that the machine is properly connected to the electrical source. The electrical requirements depend on the machine type and features. For this information, please see the machine electrical diagram provided with the machine operation manual. The control panel layout for the machine is shown on the drawing.

CAUTION: Before preceding the machine operation familiarize yourself with the **EMERGENCY-STOP** button and all functions, switches and pushbuttons.

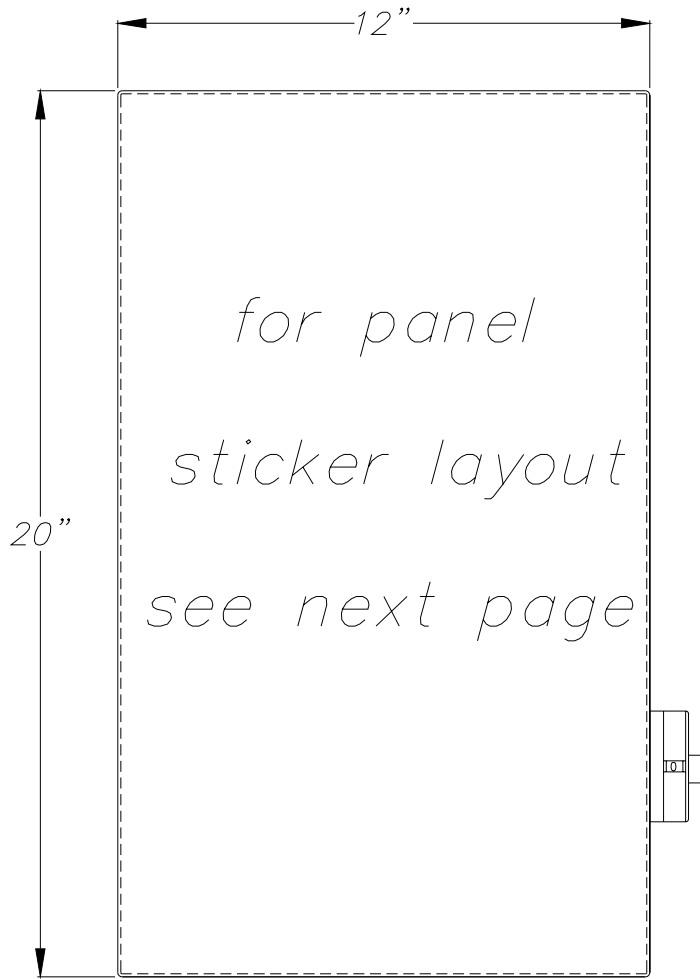

FRONT PLATE

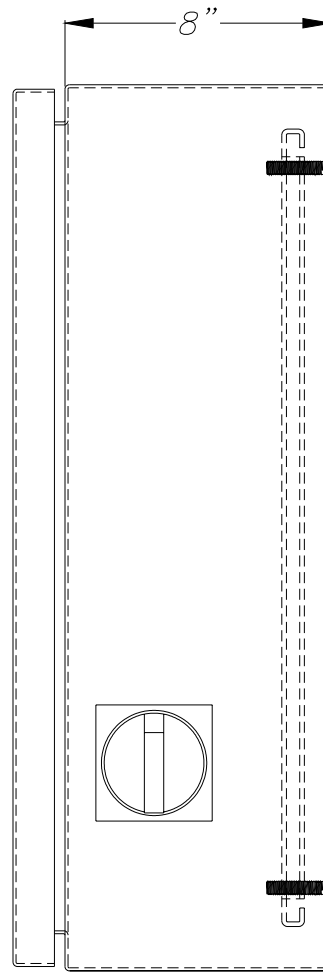

5412 ES20x12x06

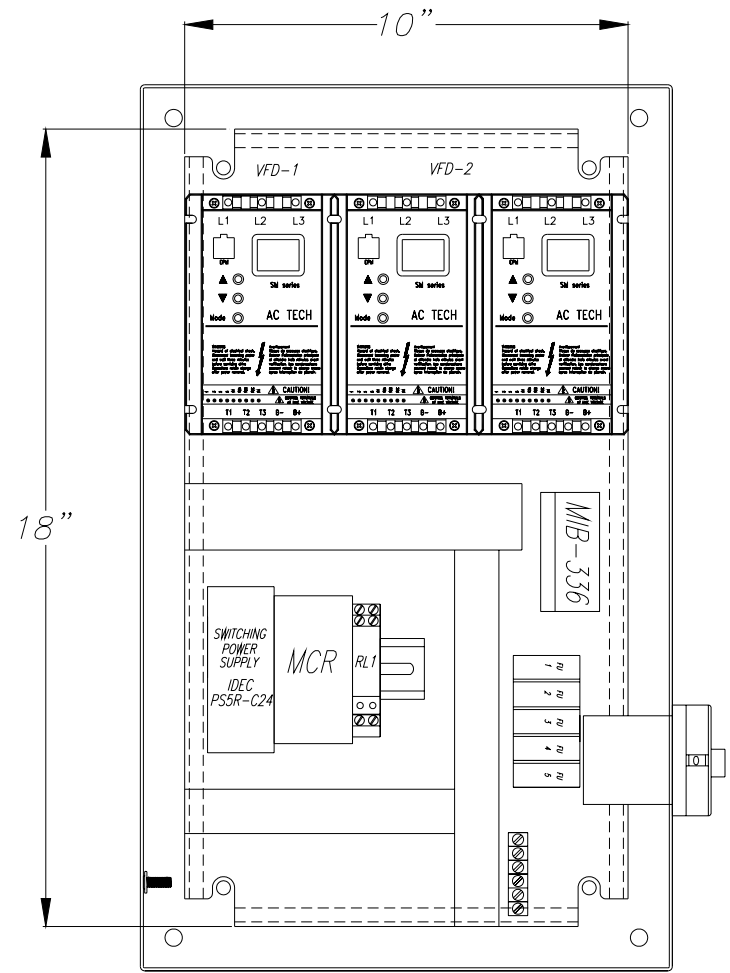

BACK PLATE



2270 INDUSTRIEL BOUL., LAVAL
QUEBEC, CANADA, H7S 1P9
TEL: (450) 667-9769

ORION PACKAGING INC.

2270 INDUSTRIEL BLVD LAVAL, QUE., CANADA H7S 1P9 SCALE: 1:2
TEL: (450) 667-9769 FAX: (450) 667-6320
APPR. BY: J.B.S. DRAWN BY: J. ALEXANDER

TITLE: HL66-20 "STANDARD"

SIZE: B DOCUMENT NO: 303 319/L REV: 2
JOB # STD

DATE: NOV-01-2006 SHEET: 1 OF 1

FILENAME: H66-20L.DWG BASE:

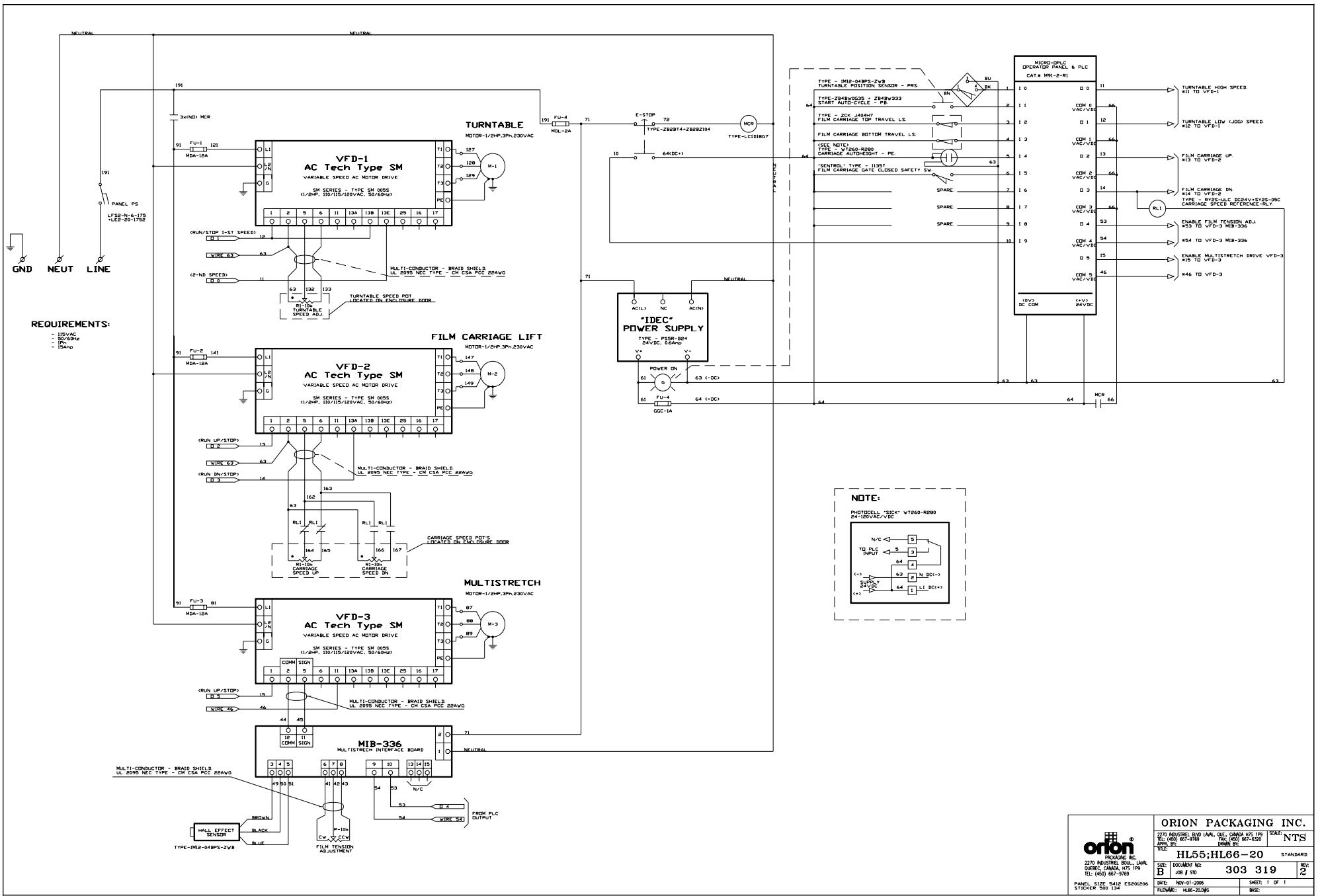

Note: For VFD adjustment, please contact Orion Packaging service department.

<p>ORION PACKAGING INC. 2270 INDUSTRIAL BOUL. LAVAL QUEBEC, CANADA, H7S 1P9 TEL: (450) 667-9789</p>	ORION PACKAGING INC. 2270 INDUSTRIAL BOUL. LAVAL, QUE. CANADA H7S 1P9 TEL: (450) 667-9789 FAX: (450) 667-9780 APPR. BY: (NAME)		3042 3042
	HL55;HL66-20		STANDARD
	SIZE: 303 319 33	DOCUMENT NO: 303 319	REV: 2
	PANEL: 512E 541E ES2010S STICKER 500 134	DATE: NOV-01-2006 FILENAME: HL66-20.DWG	SHEET: 1 OF 1 BEE:



START



STOP



1	TOP WRAPS	T (1-9)	▲ ▼	7	TABLE JOG	
2	BOTTOM WRAPS	B (1-9)	▲ ▼	8	TABLE SPEED	▶ 8 (Fix/Adj)
3	REINFORCED WRAPS	R (1-9)	▲ ▼	9		
4	AUTOHEIGHT EYE	4 (off/on)	▶	▲ ▼ CARRIAGE JOG UP/DOWN		
5	WRAP SPIRAL	5 { a- Up & Down b- Up Only	▶	P R PAUSE / RESET		
6	WRAP ORDER	6 { c- Top First d- Bottom First	▶			

WARNING! DISCONNECT POWER TO THE MACHINE BEFORE OPENING THE PANEL. DANGEROUS OR FATAL ELECTRIC SHOCKS MAY RESULT IF POWER TO THE MACHINE IS NOT DISCONNECTED BEFORE OPENING THE PANEL.

PN 500 145

Orion Packaging Systems, Inc :: Collierville, Tn, USA / Laval, Qc, Canada :: www.orionpackaging.com

MACHINE OPERATION

POWER SWITCH

Located on the panel door or side of the panel box, the lockable power switch has two settings:

- ON - connects a power source to the machine
- OFF - disconnects the power source.

START AND EMERGENCY STOP SWITCHES

The START switch is used to start the cycle once the load is on the turntable. The cycle may be stopped at anytime by pressing the STOP button. (see **Figure 1**)



Figure 1

NOTICE: The STOP button interrupts the entire machine electrical circuits. To continue the cycle the STOP push/pull button should be pulled out and START button pressed for the machine to restart. Double pressing the push – pull STOP button will reset the machine program and machine will be ready to apply the wrapping cycle from the beginning.

SETTING-UP MACHINE PARAMETERS

Note: Parameter change is available when machine is not in cycle.

1- TOP WRAPS 1,2,3...9

Press button #1 on the keypad to select “Top Wrap”, then using the arrows on the keyboard select between 1 to 9 for required number of wraps on top of the load.

2- BOTTOM WRAPS 1,2,3...9

Press button #2 on the keypad to select “Bottom Wrap”, then using the arrows on the keyboard select between 1 to 9 for required number of wraps at the bottom of the load.

Note: Refer to the list of options at the bottom of the panel sticker for reference. (see **Figure 3**)



Figure 2

3- REINFORCED WRAPS

This application allows you to apply extra wrap around the load (overlap) to reinforce and stabilize the load on the pallet. When ever you feel like adding extra wrap, simply press the #3 button and the carriage will stop moving. Machine is preset to apply 1 extra lap around the load, but you can increase that up to 9, by using the arrow.



Figure 2

4- AUTOHEIGHT EYE

Press button #4 on the keypad to switch from ON to OFF, or vice-versa.(see **Figure 3**)

ON - When ON, the photocell is activated to automatically detect top of the load. The carriage will automatically stop at the top of the load regardless of its height.

OFF - When OFF, the photocell is inoperative and carriage will travel to the top limit switch regardless of its height.

NOTE: For proper machine operation, top limit switch position should be adjusted to desired level prior to starting the cycle.

5- WRAPPING SPIRAL ; UP & DOWN OR UP ONLY

Press button #5 on the keypad to switch from UP ONLY to UP & DOWN, or vice-versa.

UP ONLY- When the UP ONLY position has been selected machine will first wrap bottom of load applying selected number of bottom wraps. The film carriage will then move to the top of load and stop. Selected number of top wraps will then be applied, after which the turntable will slow down and stop in home position. Wrap pattern "SPIRAL UP ONLY" has been completed.

UP & DOWN - This Selection has two Sub-Modes, programmable to enable the machine to perform the two different wrap patterns (Bottom Wraps First and Top Wraps First ; See wrap order #6). (Figure 4)



Figure 4

6- WRAP ORDER

TOP WRAPS FIRST - When this Sub-Mode has been selected film carriage will move to top of load and stop. Selected number of top wraps will be applied. The film carriage will then move to bottom of the load and stop. Selected number of bottom wraps will then be applied. The film carriage will be in bottom position; turntable will slow down and stop in home position.

BOTTOM WRAPS FIRST - When this Sub-Mode has been selected machine will first wrap bottom of load applying selected number of bottom wraps. The film carriage will then move to top of load and stop. Selected number of top wraps will then be applied. The film carriage will move down to bottom position, after which the turntable will slow down and stop in home position.

7- TURNTABLE JOG

The turntable jog can operate only when machine is not in cycle. The turntable jog will rotate at a low speed when the button #7 is held down, when released, the turntable will stop.

8- TABLE SPEED

The option has two setting, fix or adjustable. When set to fix, the turntable speed is constant and can not be change by the knob(knob is inactive). When set to adjustable table speed knob is active and can be used to control the speed of the table during the operation mode.

IMPORTANT:
TURNTABLE SPEED NOT TO BE ADJUSTED DURING THE WRAP CYCLE.

FILM TENSION

Film tension may be adjusted using the film tension control knob (see Figure 5). The range of tension is from 0 to 10 (0 to 4 the low range, 4 to 8 the most selected range for most of the films used by our customers, 8 to 10 as a very high range which may break some types of films).



Figure 5

CARRIAGE SPEED (Film Overlap)

The carriage speed knob can be used to control the amount of film overlap apply during the wrap. The potentiometer has settings from 0 to 10, the higher the settings the faster the speed. High settings apply less film overlap due to faster carriage speed. Low settings apply more film overlap due to lower carriage speed.

This machine is equipped with independent speed adjustment for travel up & down. (see Figure 5)

MACHINE WRAPPING TEST

Notice: It is advisable to test-run the equipment with several pallet loads before attempting to wrap using film. Please position the operator beside the EMERGENCY STOP push button. Start up of the machine (system) may determine the need for the adjustment of:

- Load height stop photoswitch (on the carriage)
- Top limit switch position
- Bottom limit switch position
- Roping bar height adjustment

Before the test procedures adjust the wrapping cycle parameters i.e. top wraps, bottom wraps, height photocell on/off, film tension, carriage speed (Last two parameters may be adjusted during the wrapping cycle).

LOADING THE FILM

The film roll can be loaded on the carriage mandrel from either end of the roll. When using tacky film, please verify that the inward tacky surface of the film is inward on the load.

1. Disconnect power (turn off power switch).
2. Swing up the top mandrel spool.
3. Put the roll of film on the bottom mandrel.
4. Install the top mandrel on top of the roll to prevent upward movement.
5. Pull the handle marked PULL TO OPEN to open film distributor cradle.
6. Pass the roped tail of the film through opening (as shown on the film quick threading pattern DWG. # 418180 Fig.1).
7. Close the film distributor cradle by pushing bar marked PUSH TO CLOSE.
8. When the film feeding is completed (fig. 2) – turn the power switch on.
9. Peel off the first few winds of the film (multistrech will run due to displacement of the dancer roller) and fix the film end onto the load.

The system is now ready to begin the first wrapping cycle.

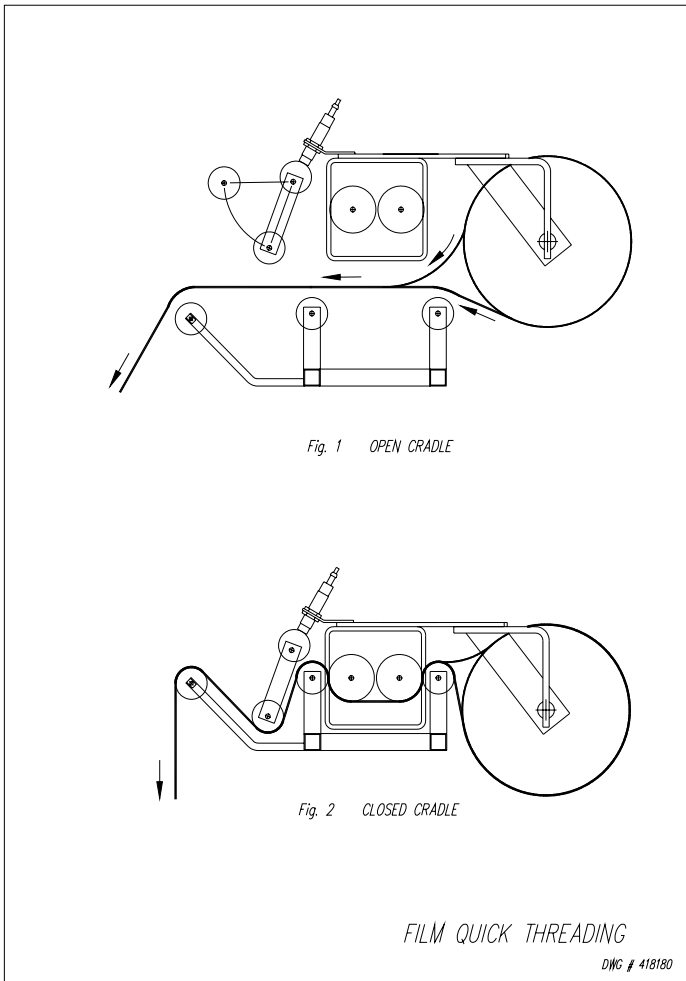

ADDITIONAL SPACER WASHER

(IF NEEDED ONLY)

The roll of film may be slightly different from time to time, so you might have to change the bottom spool spacer (washer). The only thing you have to do is to add or remove the spacer washer under the bottom spool. With the machine there is 1 washer under the bottom spool (432322), and you have received with the machine 2 extra washer to be use if needed.

Note: The bottom of the film should not be lower than the chamfer of the aluminum strip as shown on the drawing below.

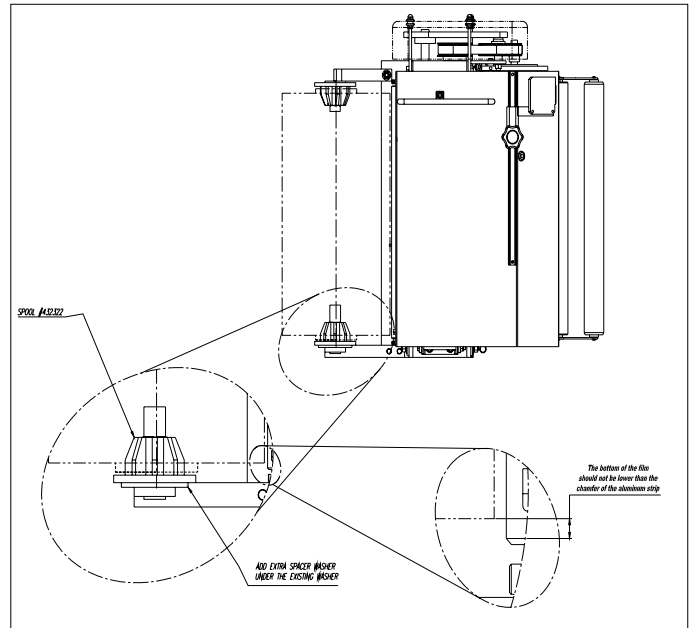

PROXIMITY SENSOR ADJUSTMENT

Occasionally the Feed Back Proximity Sensor may need some adjustment. The position of the feed back proximity sensor against the cam is shown on drawing # 419139 and on **Figure 6**.

Adjustment instructions:

- Power down machine.
- Remove the carriage cover.
- Unbolt the two nuts holding the proximity switch - item # 1.
- Turn the Proximity sensor - (item # 2) to create the gap between the cam and the front side of proximity sensor about 1/8 ".
- Tighten on the nuts securing the Proximity Sensor.
- Put the cover back on.
- Power up machine.
- Turning the trim pot SPAN adjust the moment when motor starts to turn when dancer roller moved from its home position up to 1 1/2".
- If not satisfied repeat the procedure.



Figure 6

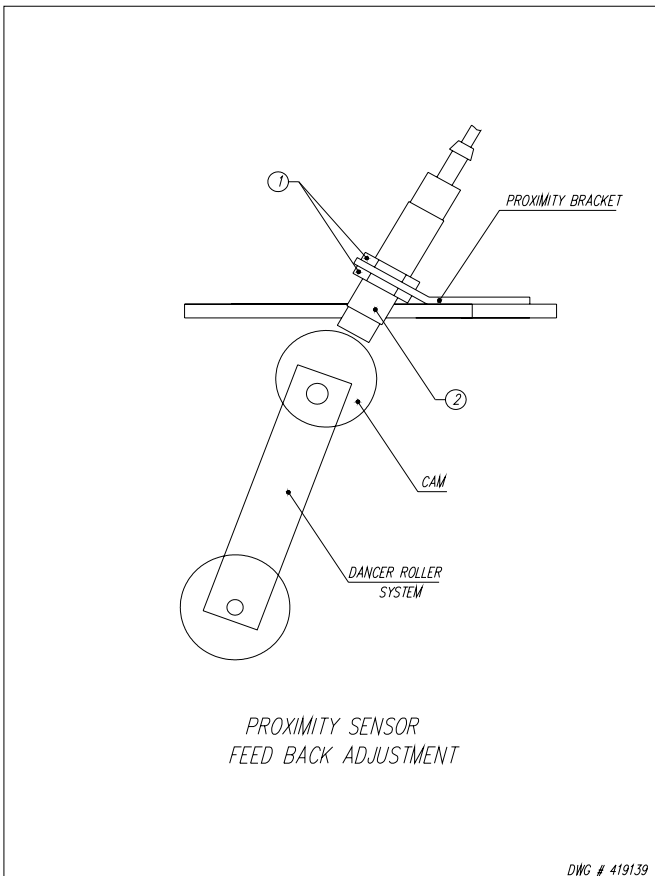

MACHINE MAINTENANCE

All general information about machine maintenance is based on normal machine working conditions: indoor, moderate dust and low moisture environment, and maximum rotation of 32 RPM of turntable/rotary arm. They should be regarded as guidelines, reviewed and corrected according to requirements of actual use and conditions.

MOTOR MAINTENANCE

An occasional inspection of the brushes should be made in order to establish a wear rate. Replacement brushes should be installed before old brushes wear to 9/16" long, measured on the long side. After replacing brushes run the motor near rated speed for at least 1/2 hour with no load to seat the new brushes. Failure to properly seat the new brushes may cause commutator damage and rapid wear of the new brushes. If the commutator becomes rough, scored or out of shape, a competent motor shop should disassemble it and resurface the commutator. With every third brush change, have a competent motor shop resurface the commutator and blow the carbon dust out of the motor.

REDUCER OIL CHANGE

All external cap screws and plugs on the reducing transmission should be checked for tightness after the first week. It is recommended to change the oil every six months or at least 1800 hours of operation, whichever comes first. When adding or changing oil, the transmission should never be filled above the oil level mark indicated, because leakage and overheating may occur. Below is the list of the type of lubricant that should be used. List of recommended reducer oils:

Manufacturer	Lubricant
American Oil Co.	American Cyl Oil no: 196-L
Cities Service Oil Co.	Citgo Cyl Oil 100-5
Gulf Oil Corp.	Gulf Senate 155
Mobil Oil Corp.	Mobil 600 W Suer-r Cyl. Oil
Philips Oil Corp.	Andes S 180
Texaco Inc.	624 + 650T Cyl.Oil
Shell Oil Co.	Velvata Oil J82
Union Oil of Cal.	Red Line Worm Gear Lube 140

RING BEARING MAINTENANCE (when applicable)

The ring bearing (located under the turntable) should be re-lubricated internally and externally.

Internally: by injecting grease into all the lubrication nipples in succession until a collar of fresh grease appears around the perimeter of the ring. The re-lubrication interval suggested for these bearings, used in Stretch Wrapping Machinery is 750 hours, with a maximum period of 6 months. The lubricant should be fresh and applied in sufficient quantities to make sure all surfaces are lubricated.

Externally: by lubricating and wiping the chain drive with oily cloth. The frequency of lubrication depends on entirely upon the usage of the machine and environment in which the machine is placed (dust, moisture etc.). Machines working under extremely dirty conditions should be lubricated every 400 operating hours but at minimum, every 2 months. Longer lubrication intervals may occur only when machine is working under very clean and dry conditions but should be not be longer than 6 months.

List of recommended lubricants for the ring bearing lubrication

Manufacturer	Lubricant
BP	Energrease LS2
Castrol	Speeroll AP2
Esso	Beacon 2
Gulf	Crown Grease 2
Mobil	Mobilus 2
Shell	Avania Grease RT 2
Texaco	Glissando FT 2
Valvoline	LB-2

TOWER RACEWAYS MAINTENANCE

The film distributor (carriage) is sliding on the plastic guides attached behind its back plate. The section of the tower on which the plastic guides move (raceways) should be cleaned and re-greased approximately every 600 hours of machine operation.

NOTICE: If the machine works in a dusty and corrosive environment, the raceways should be re-greased more often (at least every 100 hours).

CHAIN MAINTENANCE

To clean the chain, wipe it with an oily cloth every month. When machine is working in a dusty and damp environment, it may be necessary to repeat the cleaning operation more often. As the chain lubricants please use the most common chain lubricants on the market. With time, the chain will tend to stretch. A loose tower chain should be tightened by moving the reducer on its mounting plate. Turntable is equipped with automatic chain tensionner and does not need any adjustment.

NOTICE: First chain tension inspection must be done after the first two weeks of machine usage.

CAM FOLLOWER MAINTENANCE (when applicable)

The cam followers have deep grease pockets and do not need frequent relubrication. The portion of the tower on which the cam followers run, should be cleaned and regreased every 300 hours of operation. If the machine operates in a dusty or corrosive environment the tower should be relubricated more often.

SEMI-AUTOMATIC STANDARD ASSEMBLY PART LIST

Note :

- * Quantity listed in order of part number**
- ** The names given to the parts are generic**

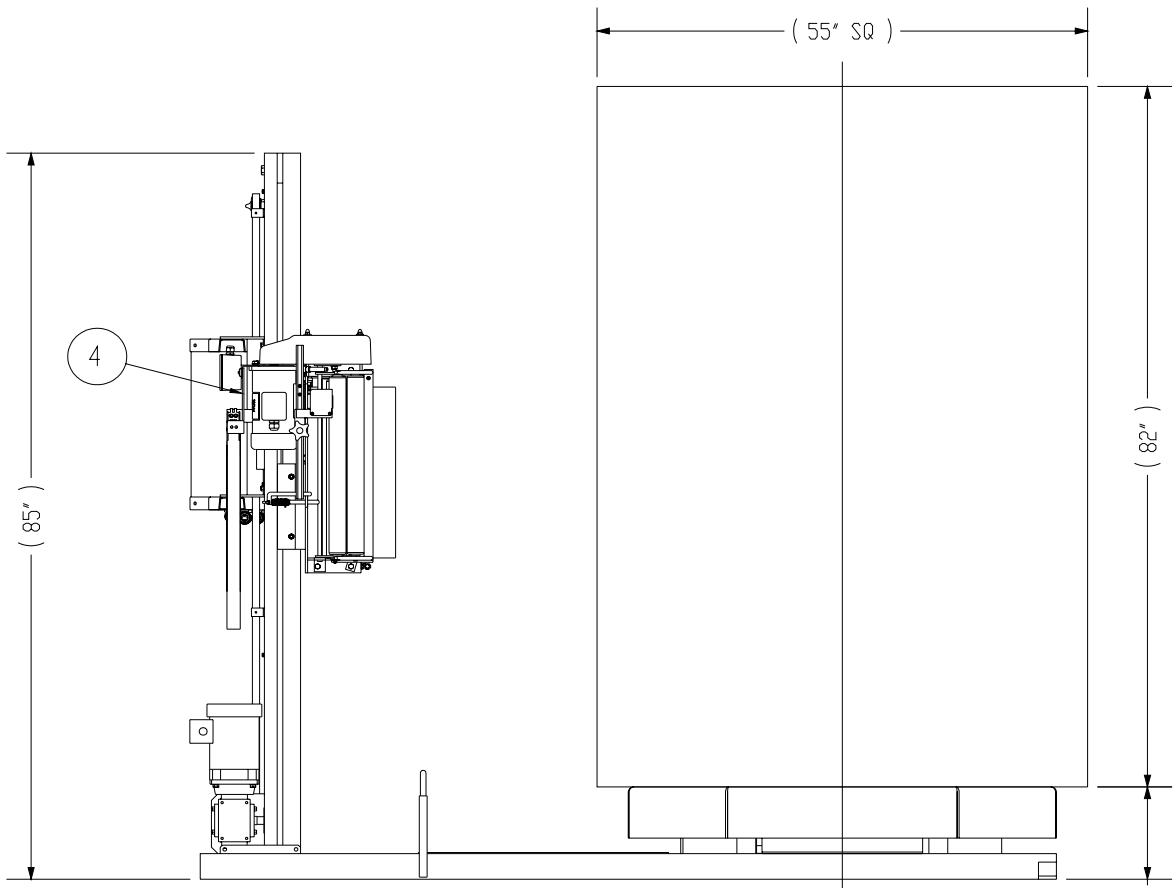
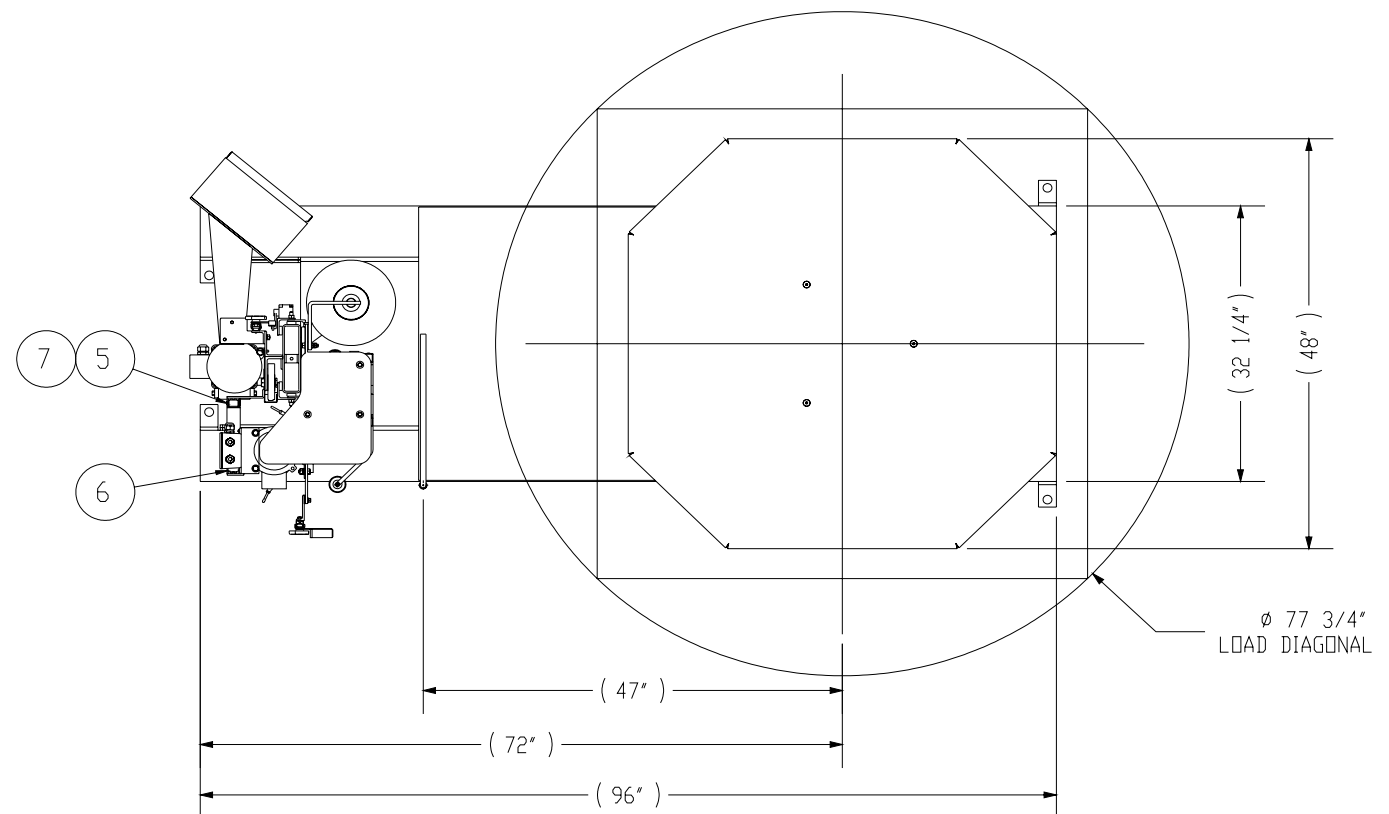

ø 77 3/4"
LOAD DIAGONAL

NOTES:

1. TURNABLE SPEED: 14 RPM MAX.
2. MAX LOAD SIZE: 55"W X 55"L X 82"H
3. WEIGHT CAPACITY: 4,000LBS
4. POWER REQUIREMENT: 115/1/60 15 AMP SERVICE
5. MACHINE COLOR: 2-TONE ORION STD GREY (PLATINUM GREY & DARK GREY)
6. 20" INSTA-THREAD FILM CARRIAGE (30" OPTIONAL)
7. 48 X 48 FORMED & WELDED OCTAGONAL TURNTABLE WITH 6" SKIRT

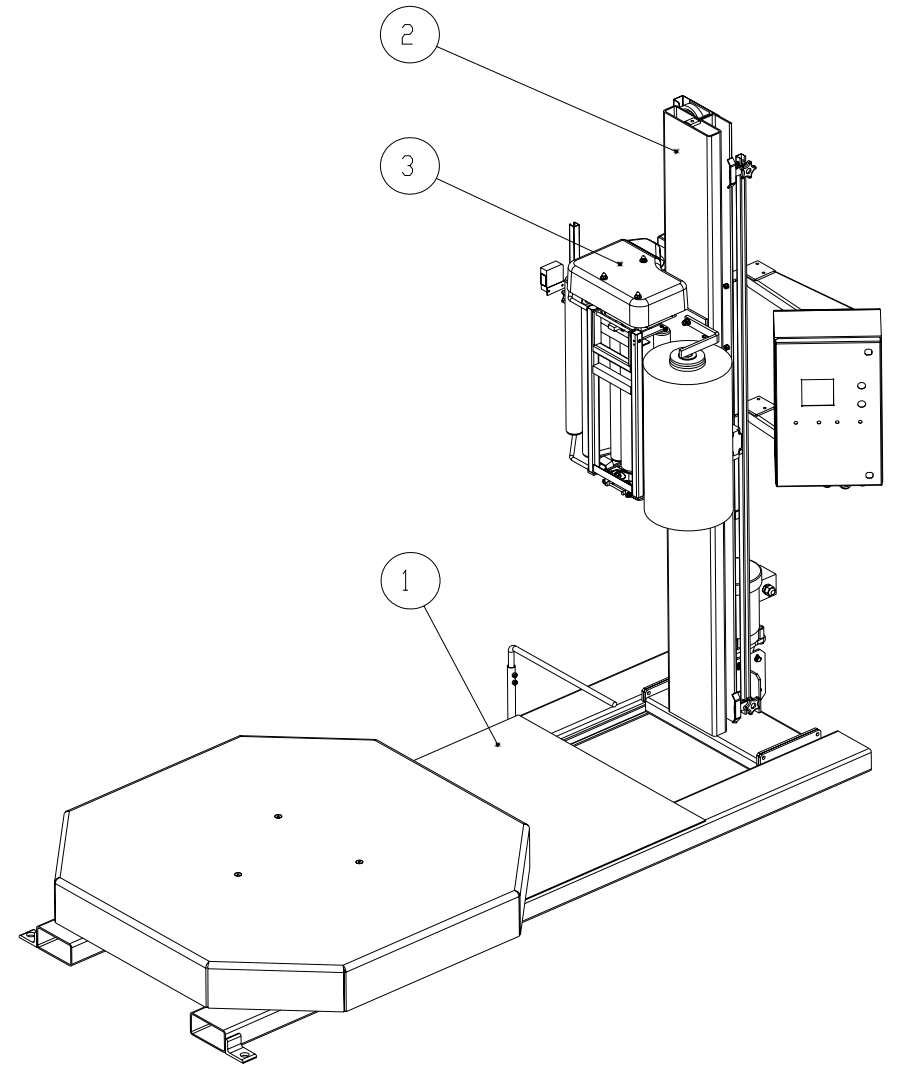

#	TITLE	Length	PART NO	QTY.
7	VERSATRAX #0345-040-025-038	52 5/8"	019053	1
6	MOVING END BRACKET		019054	1
5	FIXED END BRACKET		019055	1
4	JUNCTION BOX AND POWER TRACK BRACKET		449062	1
3	20" INSTA-THREAD ASSEMBLY (FRL)		438638	1
2	HINGE TOWER 8 x 2 - ASS'Y (STANDARD)		449377-00	1
1	H66/20 BASE ASSEMBLY (STANDARD)		449389-00	1

REMARKS

REMARKS

H66/20 LAYOUT - ASSEMBLY

<p>ORION PACKAGING INC. 2270 INDUSTRIEL, LAVAL QUEBEC, CANADA, H7S 1P9 TEL: (450) 667-9769</p>	<p>TOLERANCES UNLESS OTHERWISE SPECIFIED</p> <p>MACHINE: 15/64 WELDED: 1/16 ANGLE: 1/16 XXX: 1/16 XXXX: 1/16</p>	<p>DRAWN BY G.PETRAZZUOLI</p> <p>APPROVED BY</p>	<p>DRAWN DATE OCT/24/2006</p> <p>APPROVED DATE</p>	<p>WEIGHT (LB) 1517.08</p> <p>SCALE 1:22</p> <p>SHEET 1/1</p>
	<p>REFERENCE DWG</p>	<p>MACHINE TYPE H66/20</p> <p>ASSEMBLY DWG</p>	<p>DWG SIZE B</p>	<p>DWG NO. 449392M</p>

CE DESSIN EST CONFIDENTIEL ET NE DOIT PAS ETRE REPRODUIT OU UTILISE SANS LE CONSENTEMENT DES EMBALLAGES ORION INC.

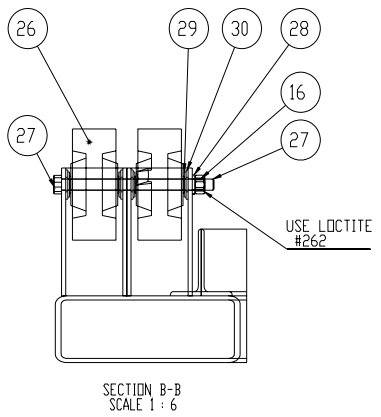
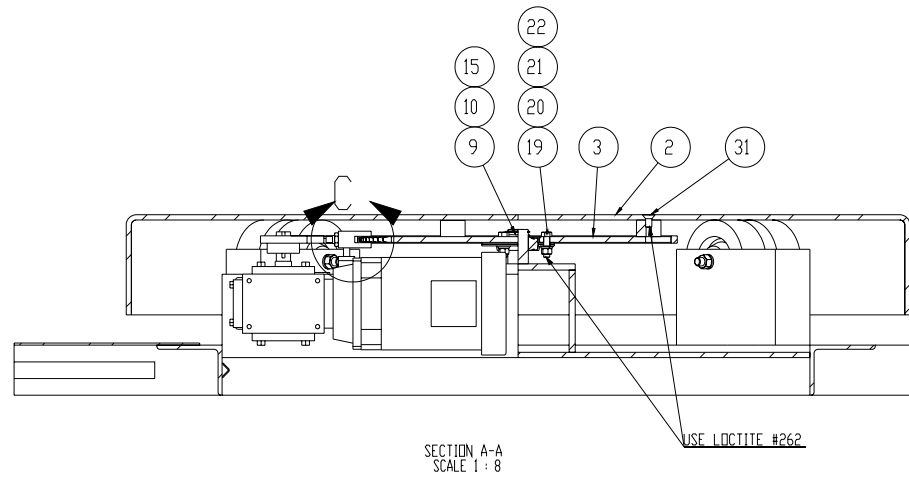
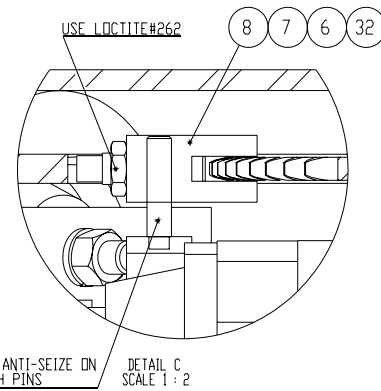
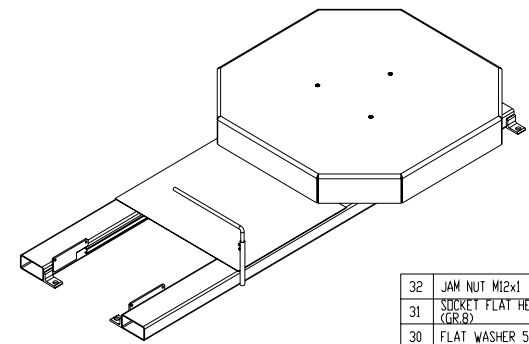
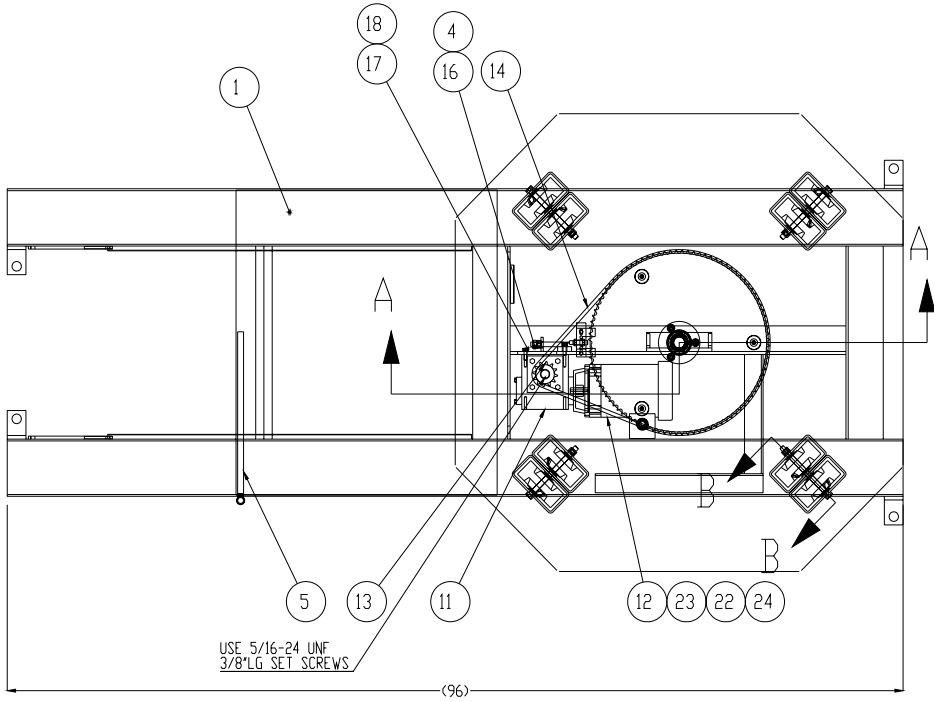

32	JAM NUT M12x1		013041	2
31	SOCKET FLAT HEAD SCREW 3/8-16NC x 3/4" (GR.8)		012692	3
30	FLAT WASHER 5/8"		012930	16
29	FLAT WASHER 1/2"		012584	16
28	LOCK WASHER 1/2"		012583	4
27	HEX BOLT 1/2-13NC X 7.000		015296	4
26	PHENOLIC WHEEL 5 DIA X 2		015350	8
25	SEALING WASHER 1/2"		010650-3	1
24	NUT LOCK 1/2"		010650-2	1
23	PLASTIC CONNECTOR 1/2"		010650-1	1
22	HEX NUT 3/8-16NC		011128	3
21	LOCK WASHER 3/8"		011390	3
20	FLAT WASHER 3/8"		010948	3
19	HEX BOLT 3/8-16NC x 1 1/4"		012406	3
18	LOCK WASHER 5/16"		012724	4
17	HEX BOLT 5/16-18NC x 1"		010316	4
16	HEX NUT 1/2-13NC		011266	6
15	EXTERNAL RETAINING RING - 1 1/4" SIZE		013655	1
14	CHAIN #50, 109 LINKS + C/L	68 1/8"	010009	1
13	SPROCKET 50B12, 7/8" BORE		010435	1
12	EL. MOTOR 1/2HP, 208-230/460VAC, 1725 R.P.M.		015225	1
11	REDUCER CFC-175, 151, RIGHT, 56C		015191	1
10	HOUSING PF-206		014487	2
9	BEARING RINGBALL SA 206-20		013689	1
8	PROXIMITY SWITCH BRACKET	3"	433743	1
7	PROXY GUIDE ASS'Y		433744	1
6	PROXIMITY SWITCH BASE BRACKET	1"	434849	1
5	ROPING BAR	23 1/8"	413868	1
4	CHAIN TIGHTENER (80-175) ASS'Y		412261	1
3	SPROCKET 50A96 - H55		429603	1
2	TURNTABLE - 48" OCTOGONAL		412405	1
1	H66/20 BASE WELDING (STANDARD)		449388-00	1
#	TITLE	Length	PART NO	0

REMARKS				
REMARKS				
H66/20 BASE ASSEMBLY (STANDARD)				
 ORION PACKAGING INC. 2270 INDUSTRIAL LINK DORIC, CANADA H7S 1P3 TEL: (416) 667-9169	TOLERANCES UNLESS OTHERWISE SPECIFIED	DRAWN BY GPETRAZZUOLI	DATE DCT/24/2006	WEIGHT (KG) 676.16
	FINISHES H66/20 H66/20 H66/20 H66/20	APPROVED BY	APPROVER DATE	SCALE 1:32
REFERENCE FIG.	ASSEMBY FIG.	DWG. SIZE B	DWG. NO. 449389-00M	REV A

CE DESSIN EST CONFIDENTIEL ET NE DOIT PAS ETRE REPRODUIT OU UTILISE SANS LE CONSENTEMENT DES EMBALLAGES ORION INC.

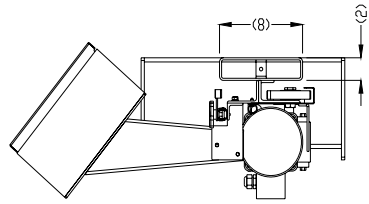

3X Ø 7/32" FIRST WALL
USE GUARD AS POSITIONING JIG
USE LOCTITE #262

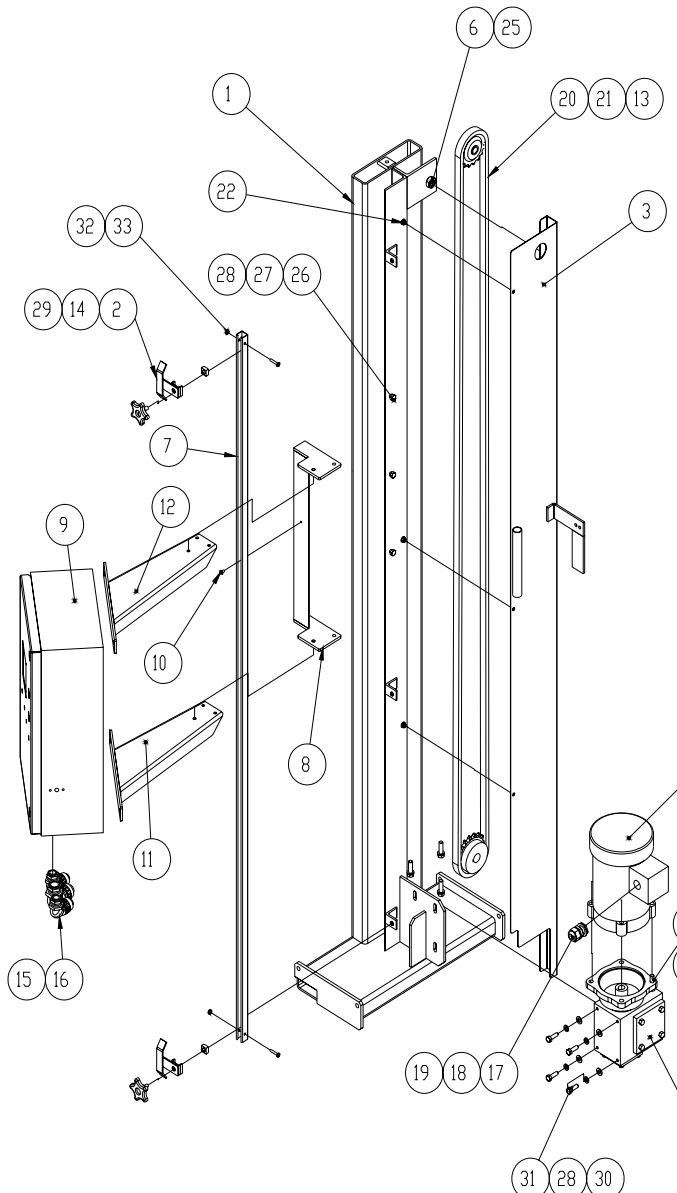
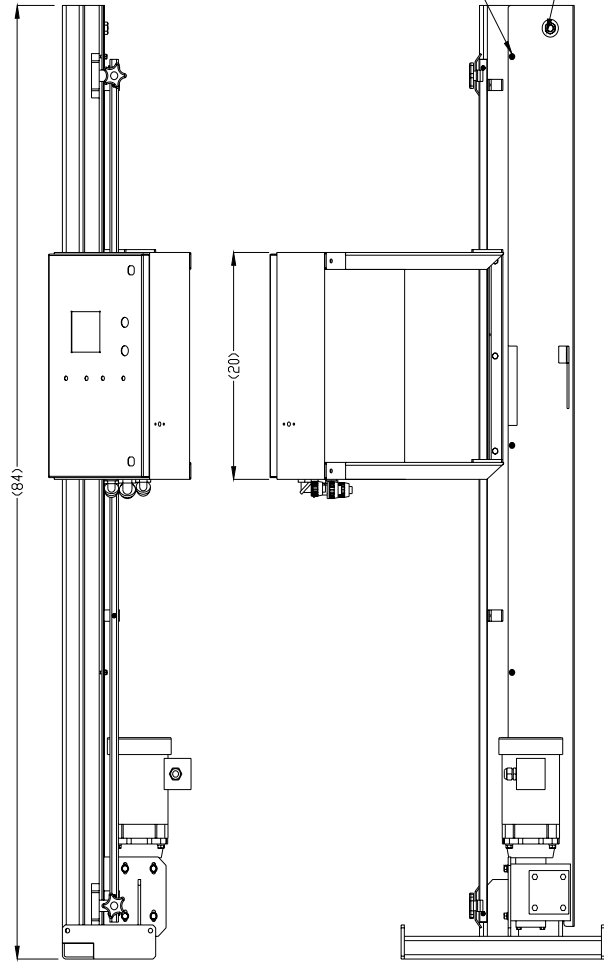

33	HEX NUT #10-24NC		012726	2
32	PAN PHILIPS HEAD SCREW #10-24NC x 1"		012690	2
31	HEX BOLT 5/16-18NC x 1"		010316	4
30	FLAT WASHER 5/16"		012725	4
29	FLAT SQUARE NUT 3/8-16NC		017853	2
28	LOCK WASHER 5/16"		012724	7
27	HEX NUT 5/16-18NC		012751	3
26	HEX BOLT 5/16-18NC x 3/4"		010382	3
25	HEX JAM NUT 5/8-18NF		014987	1
24	HEX BOLT 3/8-16NC x 1 1/4"		012406	4
23	LOCK WASHER 3/8"		011390	4
22	SCOTTED HEX HEAD THREAD FORMING SCREW 1/4-20NC x 1/2"		016142	3
21	IDLE SPROCKET AG2416		010008	1
20	CHAIN #50, 255 LINKS + C/L	159 3/8'	010009	1
19	SEALING WASHER 1/2"		010650-3	1
18	NUT LOCK 1/2"		010650-2	1
17	PLASTIC CONNECTOR 1/2"		010650-1	1
16	SWIVELLOK CONNECTOR 1/2 - PS0509NGY		017449	2
15	SWIVELLOK CONNECTOR 3/4 - PS0759NGY		017450	1
14	KNOB W/ THREADED BLIND HOLE 3/8-16NC		010092	2
13	SPROCKET 50B19, 7/8" BORE		010235	1
12	PANEL TOP BRACKET (20 X 12 X 6)		448981	1
11	PANEL BOTTOM BRACKET (20 X 12 X 6)		448982	1
10	PAN PHILIPS HEAD SCREW #10-24NC x 5/16"		013463	4
9	EL. ENCLOSURE ASSEMBLY (20 x 12 x 6)		449373	1
8	PANEL MOUNT WELDING (20 x 12 x 6)		449059	1
7	CHANNEL P-6000, STD TOWER HEIGHT	76"	428965-00	1
6	IDLER SPROCKET BOLT	1 1/2"	449571	1
5	EL. MOTOR 1/2HP, 208-230/460VAC, 1725 R.P.M.		015225	1
4	REDUCER CFC-175, 50:1, RIGHT, 56C		015200	1
3	CHAIN GUARD ASSEMBLY (H/L55,66) - STD TOWER HEIGHT		449525	1
2	STRIKER ASS'Y		427691	2
1	HINGE TOWER 8 x 2 - WELDING (STANDARD)		449376-00	1
#	TITLE	Length	PART NO	Q

REMARKS

HINGE TOWER 8 x 2 - ASS'Y (STANDARD)

<p>ORION PACKAGING INC. 2710 INDUSTRIAL LANE DEER CREEK, CANADA, T0S 1P0 TEL: (403) 667-9760</p>	<p>TOLEANCES UNLESS OTHERWISE SPECIFIED</p> <p>FRACTIONS - 1/64 DECIMALS - 0.001 DIMENSIONS - 0.001 DIMENSIONS - 0.001 DIMENSIONS - 0.001</p>	<p>DRAWN BY G.PETRAZZUOLI</p> <p>APPROVED BY</p>	<p>DRAWN DATE DCT/23/2006</p> <p>APPROVED DATE</p>	<p>WEIGHT (KG) 654.62</p> <p>SCALE 1:12</p> <p>SHEET 1/1</p>
	<p>REFERENCE DWG</p>	<p>ASSEMBLY DWG</p>	<p>DWG SIZE B</p>	<p>DWG NO 449377-00M</p>

CE DESSIN EST CONFIDENTIEL ET NE DOIT PAS ETRE REPRODUIT OU UTILISE SANS LE CONSENTEMENT DES EMBALLAGES ORION INC.

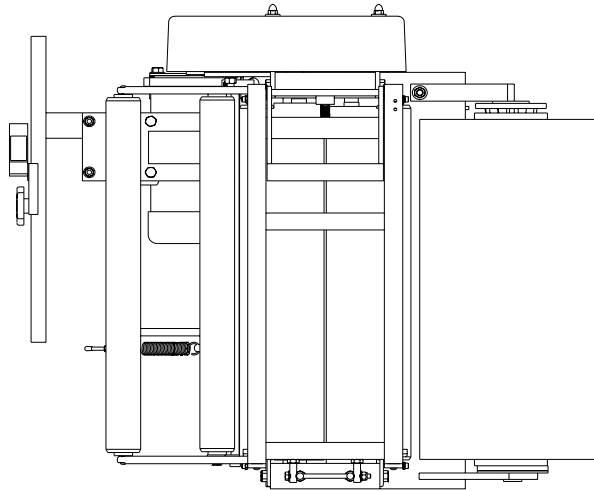
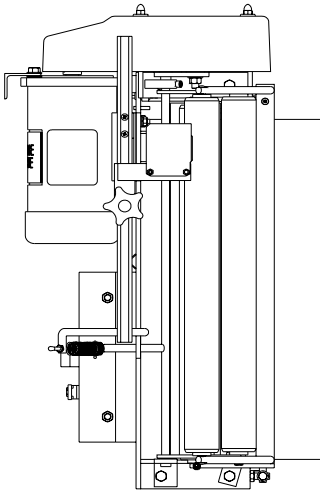
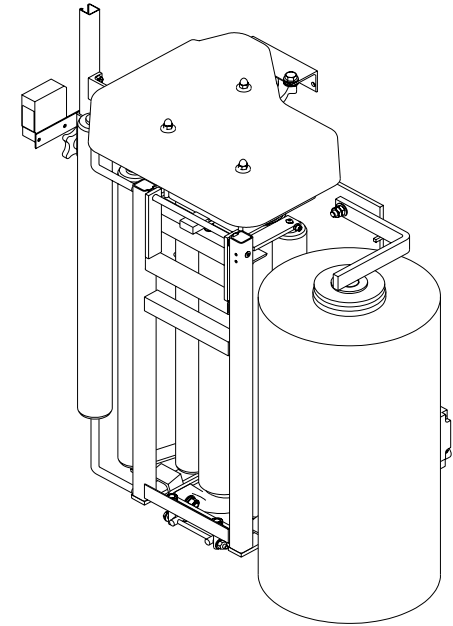
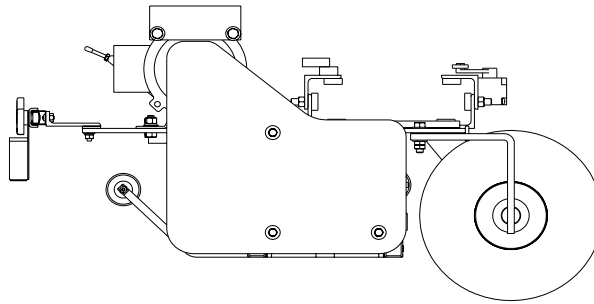
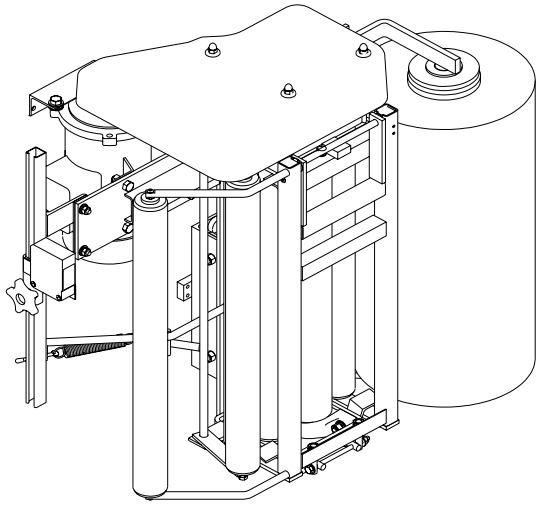

CE DESSIN EST CONFIDENTIEL ET NE DOIT PAS ETRE REPRODUIT OU UTILISE SANS LE CONSENTEMENT DES EMBALLAGES ORION INC.

REMARKS TUBULAR TOWER 8 x 2						
REMARKS BELT DRIVE						
20" INSTA-THREAD ASSEMBLY (FRL)						
 <p>ORION PACKAGING INC. 2270 INDUSTRIEL, LAVAL QUEBEC, CANADA, H7S 1P9 TEL: (450) 667-9165</p>	TOLERANCES UNLESS OTHERWISE SPECIFIED	DRAWN BY SKUBICKA	DRAWN DATE JUL/02/2003	WEIGHT (LBS) 162.93		
	MACHES - 1/164	APPROVED BY	APPROVED DATE	SCALE 1:9		
	VEED - 1/32 ANGLE - 15/32 XXX - 1/32 XXX - 1/32	PER 60°	MACHINE TYPE H.L66, 55, 44/17	JOB NO. STD	SHEET 1 / 2	
	REFERENCE DWG	ASSEMBLY DWG	DWG SIZE B	DWG NO. 438638	REV. B+	

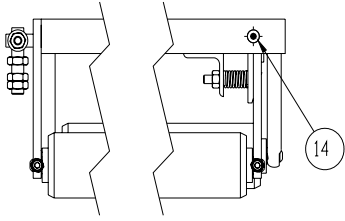

SECTION A-A
SCALE 1 : 4

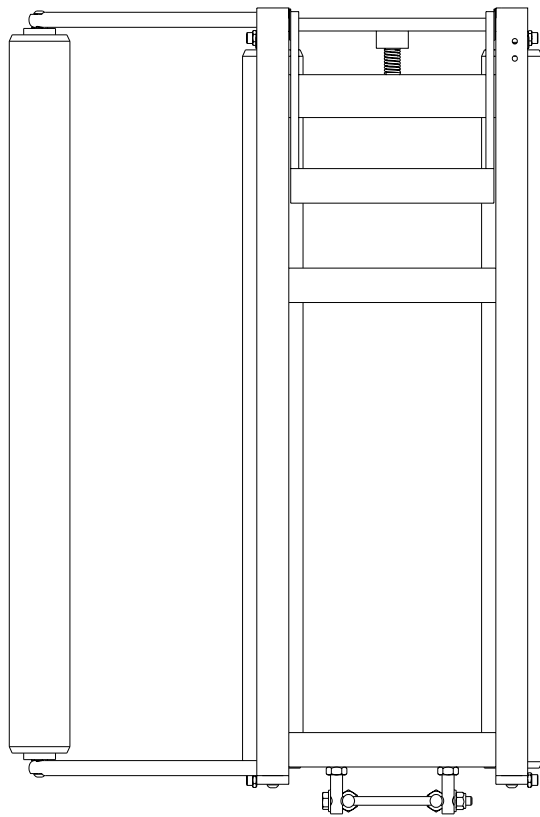

BACK VIEW

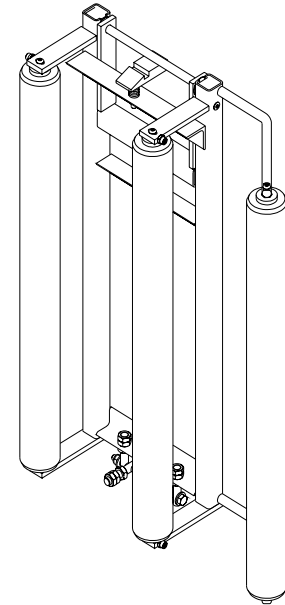
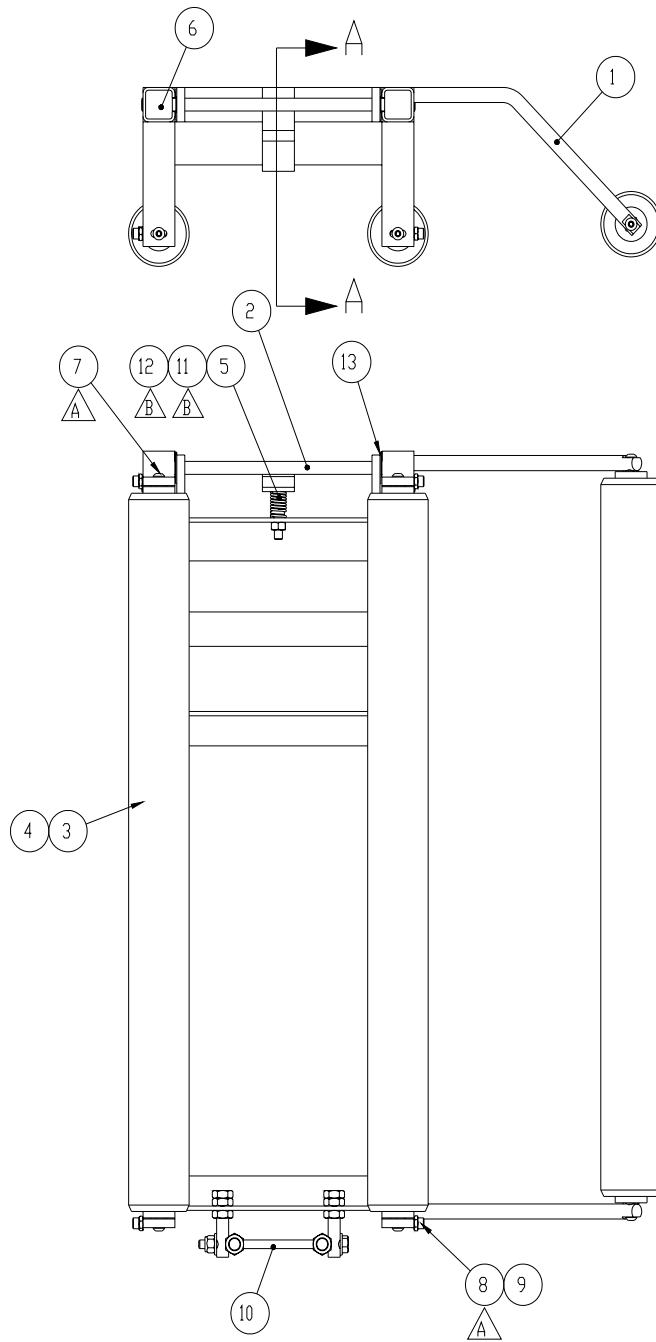

14	PDP RIVET		015534	2
13	THRUST WASHER		013144	2
12	HEX NUT		013048	1
11	SOCKET HEAD CAP SCREW		017957	1
10	CRADLE HINGE ASS'Y		426200	1
9	HEX NUT		013451	4
8	SOCKET HEAD CAP SCREW		014002	4
7	BUTTON SOCKET CAP SCREW		015133	6
6	POLYETHYLENE INSERT		431158	2
5	SPRING		013994	1
4	IDLE ROLLER SHAFT		413249	3
3	CONVEYOR ROLLER "INTERROLL"		402789	3
2	LOCK		412542	1
1	CRADLE ROLLER FRAME - 20' (FRL)		422328	1
#	TITLE	Length	PART NO	Q

REMARKS				
REMARKS				
CRADLE ROLLER ASSEMBLY - 20 (FRL)				
 2210 INDUSTRIEL, LAVA QUEBEC, CANADA, H7S 5P9 TEL: (514) 667-9169	TOLERANCES UNLESS SPECIFIC NOTED	DRAWN BY S.KUBICKA	DRAWN DATE 12/15/1999	WEIGHT (LBS) 15.30
	APPROVED BY 	APPROVED DATE	SCALE 1:6	SHEET 1 / 1
MACHINE TYPE H. L. TYPE	JOB NO. STD	ASSEMBLY DWG 422047	DWG SIZE B	DWG NO. 422327
				REV C/H

CE DESSIN EST CONFIDENTIEL ET NE DOIT PAS ETRE REPRODUIT OU UTILISE SANS LE CONSENTEMENT DES EMBALLAGES ORION INC.

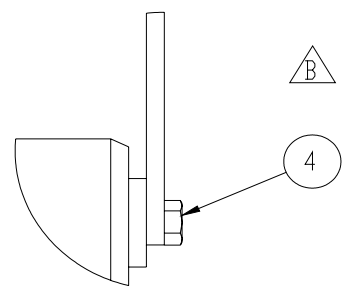
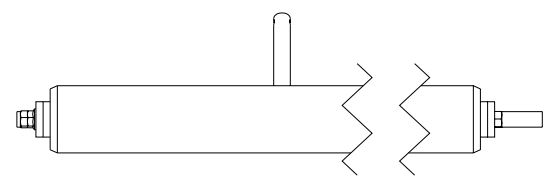
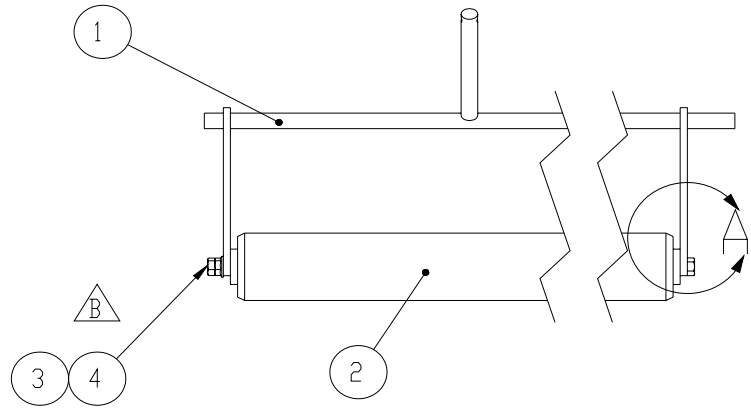

DETAIL A
SCALE 1 : 2

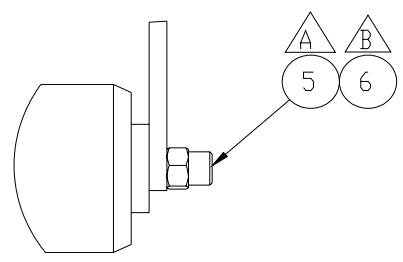

DETAIL A (S-SENSE)
SCALE 1 : 2

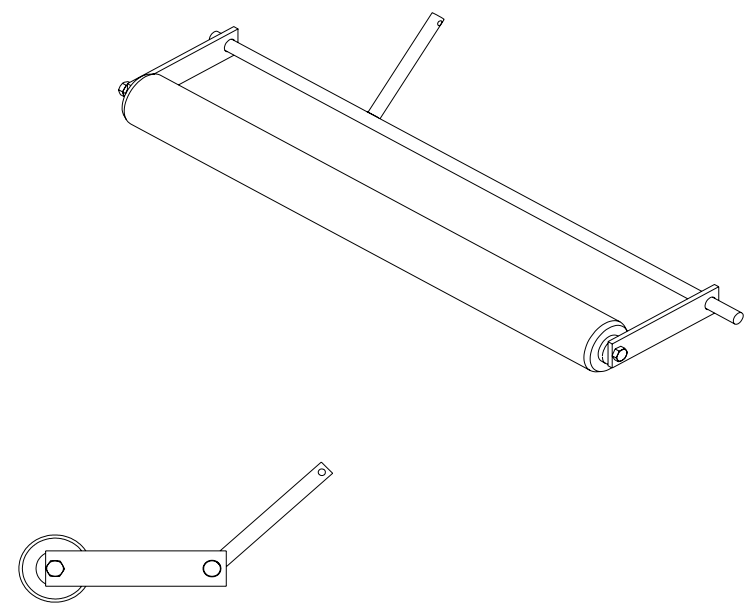

6	HEX NUT		012689	-
5	SOCKET HEAD CAP SCREW		010259	-
4	HEX BOLT		013989	2
3	HEX FLANGE NUT		014164	1
2	CONVEYOR ROLLER		402789	1
1	DANCER ROLLER CRADLE		414195	1
#	TITLE	Length	PART NO	Q

REMARKS

REMARKS

DANCER ROLLER ASS'Y - 20(FRL)

<p>ORION PACKAGING INC. 2270 INDUSTRIEL, LAVAL QUEBEC, CANADA, H7S 1P9 TEL: (450) 667-9769</p>	TOLERANCES UNLESS OTHERWISE SPECIFIED		DRAWN BY ROGER F.	DRAWN DATE 09/17/1999	WEIGHT (lb) 3.43
	MACHINED : ±1/32	60°	APPROVED BY	APPROVED DATE	SCALE 1:5
	WELDED : ±1/16		MACHINE TYPE ALL TYPE	JOB NO STD	SHEET 1 / 1
ANGLE : ±1/16		REFERENCE DWG	ASSEMBLY DWG 414189	DWG SIZE A	DWG NO 414194M
XXX : ±0.02					REV. A+
XXXX : ±0.05					

CE DESSIN EST CONFIDENTIEL ET NE DOIT PAS ETRE REPRODUIT OU UTILISE SANS LE CONSENTEMENT DES EMBALLAGES ORION INC.

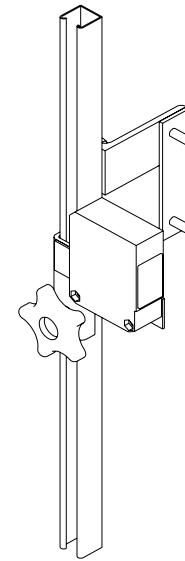
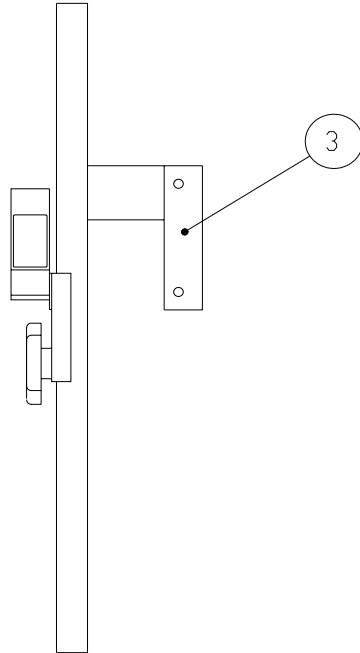
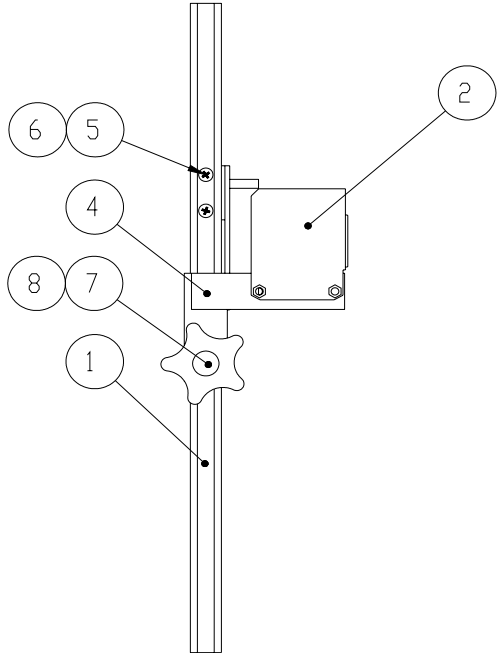
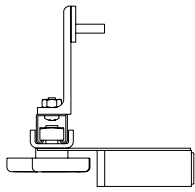

8	HEX NUT 1/4-20NC		012689	2
7	FLAT SQUARE NUT 3/8-16NC		017853	1
6	KNOB W/ THREADED BLIND HOLE 3/8-16NC		010092	1
5	PAN PHILIPS HEAD SCREW #10-24NC x 1/2"		012481	2
4	PHOTOCELL HOLDER (FLR)		436362	1
3	PHOTOCELL CHANNEL BRACKET(FRL)		429653	1
2	PHOTOCEL CHANNEL P-6000, 20" CARRIAGE	18"	429285-20	1
1	PHOTOCELL DIFFUSE, WT 260-R 280 (SICK)		017303	1
#	TITLE	Length	PART NO	Q

REMARKS

FOR INSTA-THREAD CARRIAGE

PHOTOCELL ASS'Y 20" CARRIAGE (FRL)

<p>ORION PACKAGING INC. 2270 INDUSTRIEL, LAVAL QUEBEC, CANADA, H7S 1P9 TEL: (450) 667-9769</p>	<p>TOLERANCES UNLESS OTHERWISE SPECIFIED</p> <p>MACHINED: ±1/32 WELDED: ±1/16 HOLE: ±1/16 DIM: ±0.02 XXXX: ±0.05</p> <p>REFERENCE DWG.</p>	<p>DRAWN BY M.G. GOLA</p> <p>APPROVED BY</p>	<p>DRAWN DATE 10/09/2002</p> <p>APPROVED DATE</p>	<p>WEIGHT (LBS) 1.599</p> <p>SCALE 1:5</p>
	<p>MACHINE TYPE H/L TYPE</p> <p>ASSEMBLY DWG</p>	<p>JOB NO. STD</p> <p>DWG SIZE A</p>	<p>SHEET 1/1</p> <p>DWG NO. 436361-20</p>	<p>REV. B+</p>

INC. CE DESSIN EST CONFIDENTIEL ET NE DOIT PAS ETRE REPRODUIT OU UTILISE SANS LE CONSENTEMENT DES EMBALLAGES ORION

